

Surge Protection Devices Ex9UE1+2, 12.5 kA



- Surge Protection Devices
- Type 1+2 (Class I+II, T1+T2, B+C)
- Tested according to EN 61643-11
- Max. impulse current I_{imp} 12.5 kA (10/350 μ s) per module and 50 kA for NPE module
- Maximum continuous operational voltage U_c from 275 V up to 440 V AC
- Versions with 1+0, 1+1, 2+0, 3+0, 3+1 and 4+0 connection
- Plug-in module design
- With and without remote indication contact
- Device status indicator

The Ex9UE1+2 12.5 line is a group of Class I+II Surge Protective Devices. They are intended as a protection against indirect and low intensity direct hits of lightning strokes. In standard three phase TN-C grid, they provides protection to LPL III, IV requirements given in EN 62305 with total lightning current introduced into electrical installation of 37.5 kA and total lightning stroke current 75 or 100 kA based on physical configuration and mutual position of grounding point of lightning rod, grounding point of the electrical installation and place of SPD installation.

The design of Ex9UE1+2 12.5 is based on high energy Metal Oxide Varistors. Such design provides low response time and ensures characteristics for both classes I and II. The modular design with plug in inserts allows simple and quick replacement of function modules in case of MOV is beyond if its lifespan due to high intensity or often occurrence of overvoltage peaks.

Type Key

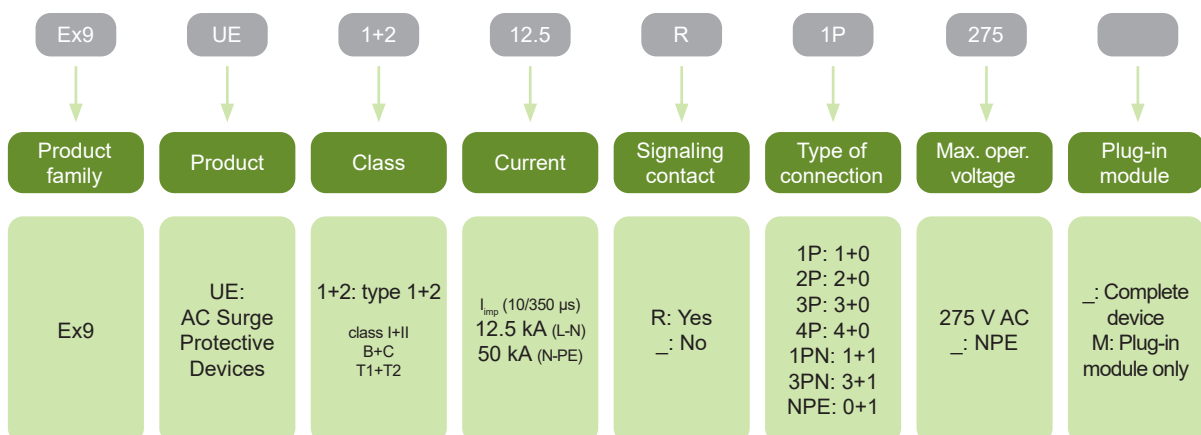

Certification marks



Surge Protection Devices Ex9UE1+2, 12.5 kA

Type 1+2 SPDs (Class I+II, T1+T2, B+C) complete devices, $I_{imp} = 12.5 \text{ kA (10/350 } \mu\text{s)}$

- Maximum impulse current I_{imp} 12.5 kA (10/350 μs) per module and 50 kA (10/350 μs) for NPE (+1) module
- Nominal discharge current I_n 25 kA (8/20 μs) per module and 50 kA (8/20 μs) for NPE (+1) module
- Maximum discharge current I_{max} 50 kA (8/20 μs)
- Maximum continuous operational voltage U_c 275 V AC per module and 255 V AC for NPE (+1) module
- Due to I_{imp} 12.5 kA per module suitable for LPL III and LPL IV according to EN 62305 in standard 3-phase TN-C and TN-S installations



Operating voltage	Connection	Signaling contact	Article No.	Type	Packing
275 V AC	1+0	no	103332	Ex9UE1+2 12.5 1P 275	1/96
275 V AC	1+0	yes	103333	Ex9UE1+2 12.5R 1P 275	1/96
275 V AC	1+1	no	103334	Ex9UE1+2 12.5 1PN 275	1/60
275 V AC	1+1	yes	103335	Ex9UE1+2 12.5R 1PN 275	1/60
275 V AC	2+0	no	103336	Ex9UE1+2 12.5 2P 275	1/60
275 V AC	2+0	yes	103337	Ex9UE1+2 12.5R 2P 275	1/60
275 V AC	3+0	no	103338	Ex9UE1+2 12.5 3P 275	1/54
275 V AC	3+0	yes	103339	Ex9UE1+2 12.5R 3P 275	1/54
275 V AC	3+1	no	103340	Ex9UE1+2 12.5 3PN 275	1/45
275 V AC	3+1	yes	103341	Ex9UE1+2 12.5R 3PN 275	1/45
275 V AC	4+0	no	103342	Ex9UE1+2 12.5 4P 275	1/45
275 V AC	4+0	yes	103343	Ex9UE1+2 12.5R 4P 275	1/45

Type 1+2 spare modules, $I_{imp} = 12.5 \text{ kA (10/350 } \mu\text{s)}$



Max. oper. voltage U_c	Max. imp. current I_{imp}	Article No.	Type
275 V AC	12.5 kA	103330	Ex9UE1+2 12.5 1P 275 M
N-PE	50 kA	103331	Ex9UE1+2 NPE M

Technical Data Ex9UE1+2

Surge Protection Devices Type 1+2, $I_{imp} = 12.5 \text{ kA}$ (10/350 μs)

General parameters

Suitable for protection of electrical installations against transient overvoltage and indirect lightning strikes
Plug-in module design
Indication window and optional remote-signaling contact helps users to know the status of device
Due to I_{imp} 12.5 kA per module suitable for LPL III and LPL IV according to EN 62305 in standard 3-phase TN-C and TN-S installations

Electrical parameters

	1+0, 2+0, 3+0, 4+0, 1+1, 3+1 (L-N/PE/PEN connection)	1+1, 3+1 (x+1 N-PE connection)
Tested according to	EN 61643-11	
Classified type (test class)	Type 1+2 (Class I+II, B+C, T1+T2)	
Technology	MOV (Varistor)	GDT (Spark-gap)
Rated operational voltage U_n	230 / 400 V AC	
Reference test voltage U_{REF}	255 V AC	
Max. continuous operational voltage U_c	275 V AC	255 V AC
Nominal frequency f	50/60 Hz	
Nominal discharge current I_n (8/20 μs)	25 kA per pole	50 kA per pole
Impulse current specific energy W/R	156.25 kJ/ Ω	
Max. impulse current I_{imp} (10/350 μs)	12.5 kA per pole	50 kA per pole
Max. discharge current I_{max} (8/20 μs)	50 kA per module	
Protection voltage U_p at I_n	1.5 kV	1.5 kV
Protection voltage U_p at I_{max}	1.8 kV	1.5 kV
Protection voltage U_p at 5 kA (8/20 μs)	1 kV	-
N-PE follow current interrupting rating I_n	-	100 A
Temporary overvoltage U_T (withstand)		
5 s	335 V	335 V
200 ms	335 V	1200 V
Residual current I_{PE} at U_{REF}	$\leq 1 \text{ mA}$	-
MOV voltage of 1mA point	387 - 473 V	
Response time	$\leq 25 \text{ ns}$	$\leq 100 \text{ ns}$
Max. back-up fuse	max. 160 A gG	-
Short-circuit withstand capability	50 kA	-
Short-circuit current rating I_{SCCR}	10 kA	-
Current factor k	1.6	-
Number of ports	1	
Type of LV system	TN-C, TN-S, TN-C-S, TT (1+1, 3+1), IT (1+1, 3+1)	
Remote contact (optional)	1 changeover (CO)	
Remote contact op. voltage / current		
AC U_{max} / I_{max}	250 V AC / 1 A	
DC U_{max} / I_{max}	30 V DC / 1 A	

Technical Data Ex9UE1+2

Surge Protection Devices Type 1+2, $I_{imp} = 12.5 \text{ kA (10/350 } \mu\text{s)}$

Table of tolerance zones at 1 mA

	Max. continuous operational voltage U_c	Voltage tolerance zone at 1mA
Ex9UE1+2 12.5	275 V	387 - 473 V
Ex9UE2 20	275 V	387 - 473 V
	320 V	459 - 561 V
	385 V	558 - 682 V
	440 V	639 - 781 V
Ex9UE2 30	350 V	504 - 616 V
	440 V	639 - 781 V
Ex9UEP 20	500/1000 V	643.5 - 786.5 V
	600/1200 V	738 - 902 V
	750/1500 V	950 - 1100 V

Mechanical parameters

Device width	17.5 mm (per pole/module)
Device height	83 mm (89 mm including rail clip)
Frame size	45 mm
Method of mounting	fixed
Mounting	easy fastening onto 35 mm device rail (DIN)
Mounting position	arbitrary
Degree of protection	IP40, terminals IP20
Terminals	combined lift + open mouthed, M5 screws
Terminal capacity	2.5 — 35 mm ²
Fastening torque of terminals	2 — 3.5 Nm
Remote contact terminal capacity	0.14 — 1.5 mm ²
Location	indoor
Ambient temperature	-40 — +80 °C
Altitude	≤ 2000 m
Relative humidity	30 — 90 %
Weight (per pole)	0.15 kg

Technical Data Ex9UE1+2

Surge Protection Devices Type 1+2, $I_{imp} = 12.5 \text{ kA} (10/350 \mu\text{s})$

Dimensions

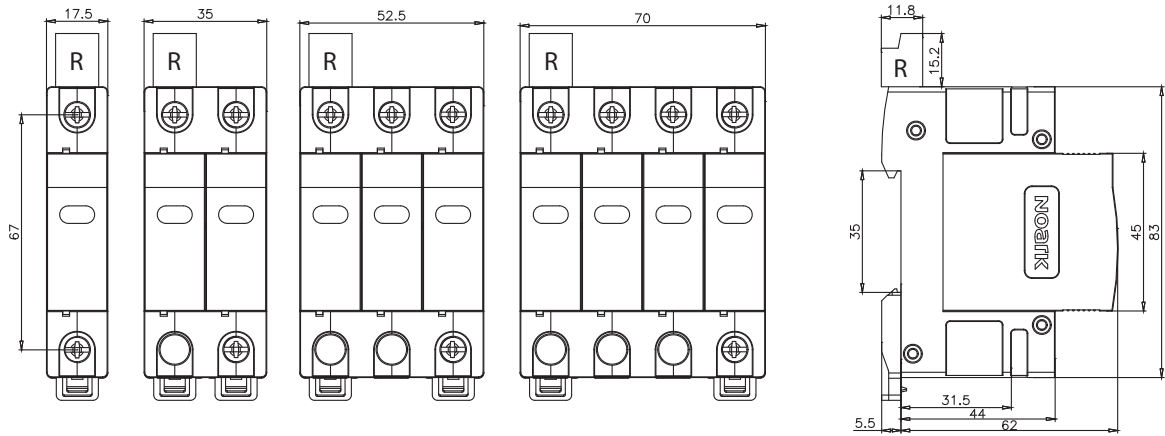

Connection diagrams, protection mode

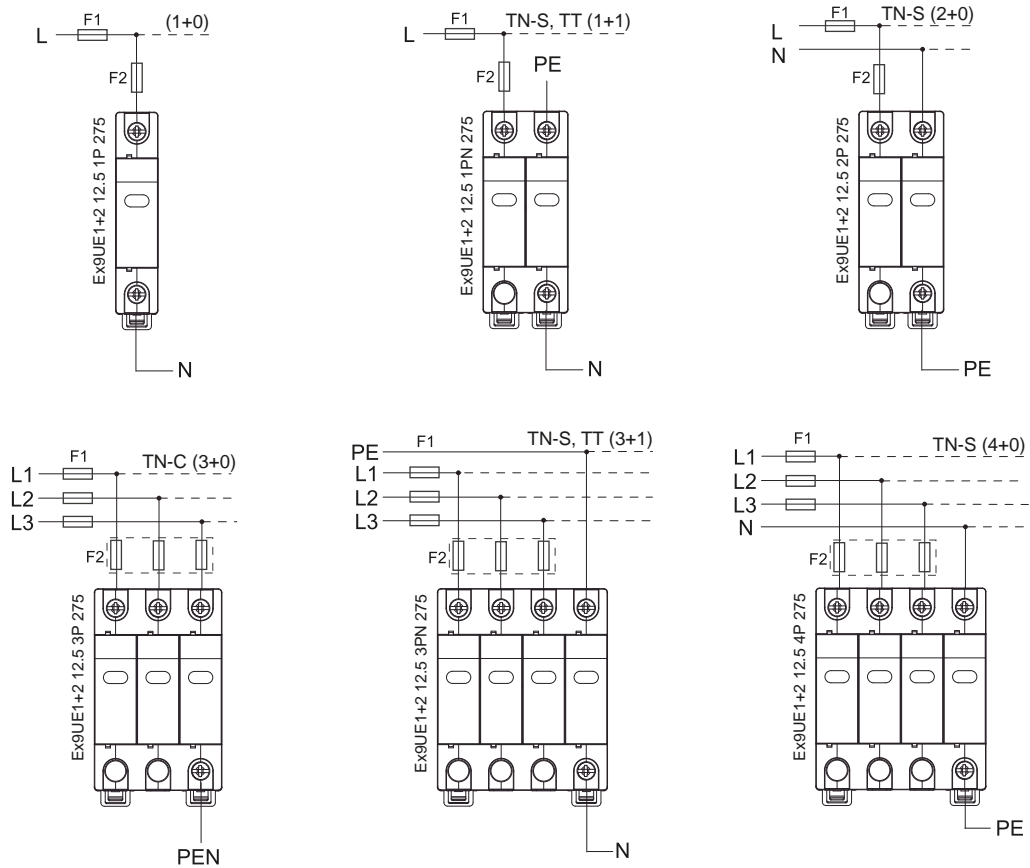

Surge Protection Devices Type 1+2 and Type 2

Wiring diagrams

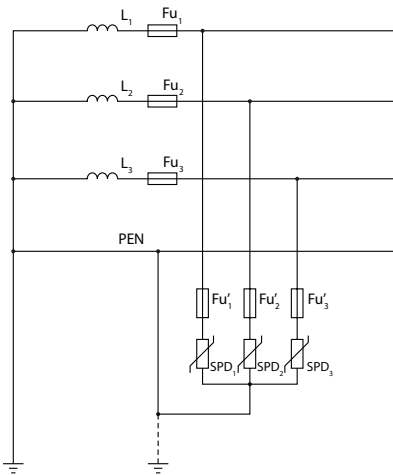

3+0 TN-C

Connection type 3+0 in TN-C system consists of three identical SPDs.

Fu_1 - Fu_3 represent main protection (fuses, circuit breaker) in the installation. In case when $Fu_1, Fu_2, Fu_3 > \text{Max. back-up fuse for given SPDs}$, Fu'_1, Fu'_2, Fu'_3 have to be used. $Fu'_1, Fu'_2, Fu'_3 \leq \text{Max. back-up fuse of the SPDs}$.

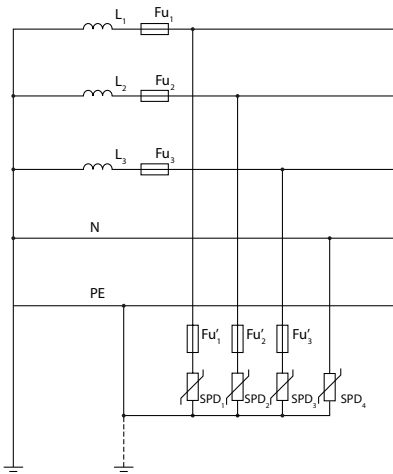

4+0 TN-S

Connection type 4+0 in TN-S system consists of four identical SPDs. This type of connection is suitable mainly to suppress longitudinal type of transient overvoltage, typically caused by atmospheric stroke. The advantages lay in uniform conducting of lightning current from phase and N-conductors. It also effectively protects insulation of conductors suffered with consecutive effects of a lightning stroke. This connection does not provide optimum protection in case transversal overvoltage (typically caused by wanted and unwanted fast switching processes) and thus it is not the best solution for protection of equipment and end consumers. It follows from the fact that residual transversal overvoltage between L and N conductors is given by protection level of two SPDs connected in a series. (e.g. Up of $SPD_1 + SPD_4$ for L_1 -N

Fu_1 - Fu_3 represent main protection (fuses, circuit breaker) in the installation. In case when $Fu_1, Fu_2, Fu_3 > \text{Max. back-up fuse for given SPDs}$, Fu'_1, Fu'_2, Fu'_3 have to be used. $Fu'_1, Fu'_2, Fu'_3 \leq \text{Max. back-up fuse of the SPDs}$.

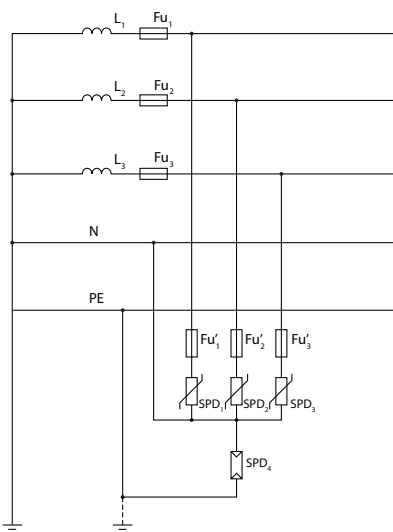

3+1 TN-S

Connection type 3+1 in TN-S system consists of three identical SPDs and one sum spark gap. It is suitable mainly to suppress transversal type of transient overvoltage, typically caused by wanted and unwanted fast switching processes. Main advantage is minimization of residual transversal overvoltage between L and N, which is defined dominantly by protection level of a single SPD. This diagram is recommended for protection of end consumers in TN-S system. A disadvantage for suppression of atmospheric longitudinal overvoltage follows from non-uniform protection of L and N conductors. When used for protection against longitudinal effects, usually as a protection against lightning stroke current (SPD class I), I_{imp} of sum spark gap SPD_4 must be min. $4 \times I_{imp}$ of SPD_1, SPD_2, SPD_3 .

Fu_1 - Fu_3 represent main protection (fuses, circuit breaker) in the installation. In case when $Fu_1, Fu_2, Fu_3 > \text{Max. back-up fuse for given SPDs}$, Fu'_1, Fu'_2, Fu'_3 have to be used. $Fu'_1, Fu'_2, Fu'_3 \leq \text{Max. back-up fuse of the SPDs}$.

Technical Data Ex9UE

Surge Protection Devices Type 1+2 and Type 2

Wiring diagrams

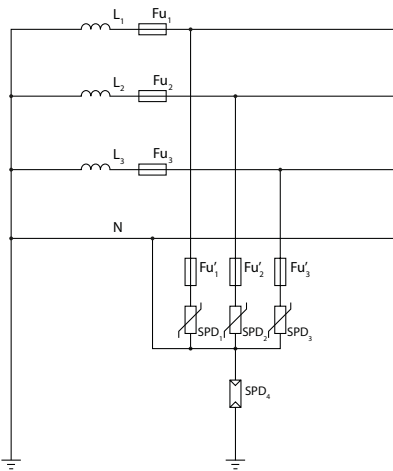

3+1 TT

In order to keep insulation status between N conductor and ground potential, connection 3+1 is recommended for TT systems. It provides maximum protection against transversal transient overvoltage and significantly limits longitudinal one.

Fu_1 - Fu_3 represent main protection (fuses, circuit breaker) in the installation. In case when $Fu_1, Fu_2, Fu_3 > \text{Max. back-up fuse for given SPDs}$, Fu'_1, Fu'_2, Fu'_3 have to be used. $Fu'_1, Fu'_2, Fu'_3 \leq \text{Max. back-up fuse of the SPDs}$.

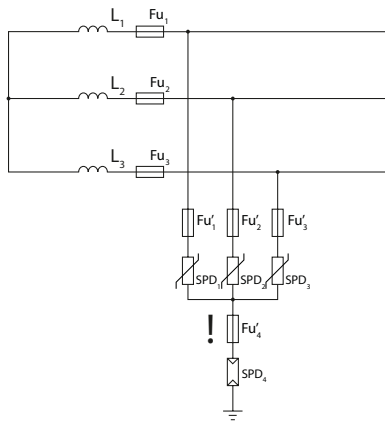

3+1 IT

3+1 connection in IT system is suitable for protection against both transversal as well as longitudinal overvoltage. Due to grounded sum spark gap allows effective reduction of effects caused by lightning currents. Particular SPDs are dimensioned to "phase" voltage of the system (i.e. to 230 V in 230/400V grid). An important difference to 3+1 connection in TN-S system is back up fuse for sum spark gap. This protection has to be used in IT systems. It ensures insulation status in case of spark gap malfunction like uninterrupted follow currents.

Fu_1 - Fu_3 represent main protection (fuses, circuit breaker) in the installation. In case when $Fu_1, Fu_2, Fu_3 > \text{Max. back-up fuse for given SPDs}$, Fu'_1, Fu'_2, Fu'_3 have to be used. $Fu'_1, Fu'_2, Fu'_3 \leq \text{Max. back-up fuse of the SPDs}$. $Fu'_4 \leq \text{Max. back up fuse of the sum spark gap SPD}_4$.

Note: Connection diagram is indicative only. There have to be observed and fulfill potential other requirements, e.g. insulation tests of sum spark gap etc., in actual IT system.

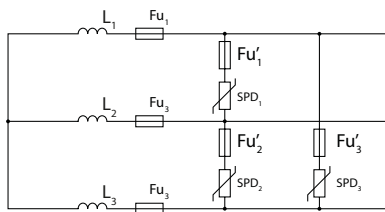

3+0 IT

This type of connection is suitable for protection against transversal overvoltage caused by switching processes. Particular SPDs must be dimensioned for phase-phase voltage.

Fu_1 - Fu_3 represent main protection (fuses, circuit breaker) in the installation. In case when $Fu_1, Fu_2, Fu_3 > \text{Max. back-up fuse for given SPDs (transformed to single phase voltage)}$, Fu'_1, Fu'_2, Fu'_3 have to be used. $Fu'_1, Fu'_2, Fu'_3 \leq \text{Max. back-up fuse of the SPDs}$.

Surge Protection Devices Type 1+2 and Type 2

Wiring diagrams

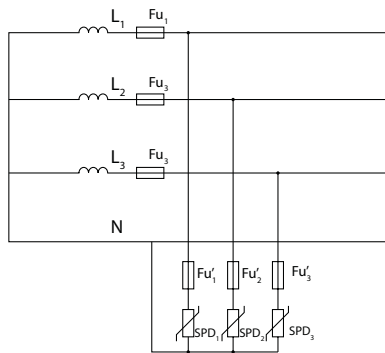

3+0 local isolated system with N conductor (hospitals, chemical industry, etc.)

This type of connection is suitable for protection against transversal overvoltage caused by switching processes. Because such system is designed in order to maximize availability of main voltage, there must be assumed first fault in the system as a standard operational regime. Due to this reason, particular SPDs must be dimensioned for phase-phase voltage (i.e. to 400 V in 230/400 V system).

Fu_1 - Fu_3 represent main protection (fuses, circuit breaker) in the installation. In case when $Fu_1, Fu_2, Fu_3 > \text{Max. back-up fuse for given SPDs}$, Fu'_1, Fu'_2, Fu'_3 have to be used. $Fu'_1, Fu'_2, Fu'_3 \leq \text{Max. back-up fuse of the SPDs}$.

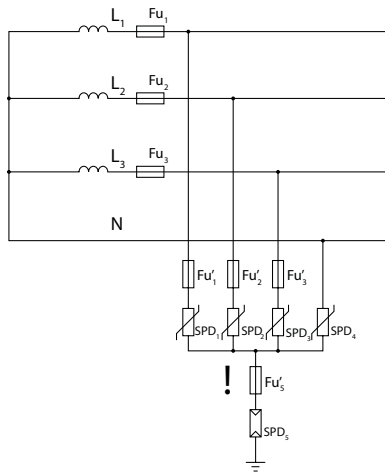

4+1 local isolated with N conductor (hospitals, chemical industry, etc.)

This connection is suitable for limitation of both transversal as well as longitudinal surges. Thanks to SPD_4 , it provides much fine and balanced protection of all phase conductors in comparison to connection 3+1. It also more effectively limits phase – phase transversal overvoltage. Particular devices SPD_1 - SPD_4 are dimensioned for phase voltage (i.e. to 230 V in 230/400 V system). As in standards IT system, sum spark gap SPD_5 has to be protected with back up fuse to ensure insulation of the system. **Local requirements on the sum spark gap have to be followed in particular applications.**

Fu_1 - Fu_3 represent main protection (fuses, circuit breaker) in the installation. In case when $Fu_1, Fu_2, Fu_3 > \text{Max. back-up fuse for given SPDs}$, Fu'_1, Fu'_2, Fu'_3 have to be used. $Fu'_1, Fu'_2, Fu'_3 \leq \text{Max. back-up fuse of the SPDs}$. $Fu_5 \leq \text{Max. back up fuse of the sum spark gap } SPD_5$.

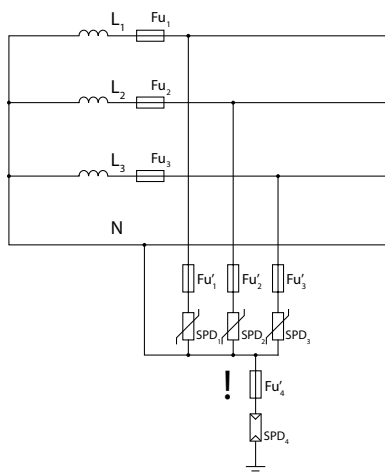

3+1 local isolated with N conductor (hospitals, chemical industry, etc.)

Situation is similar to 4+1 connection. Particular devices SPD_1 - SPD_3 are dimensioned for phase - phase voltage (i.e. to 400 V in 230/400 V system) not to be overloaded in case of the first, generally non-tripped, fault. This connection is suitable for consumers for which transient overvoltage between phase and N conductors matters most. Sum spark gap SPD_4 has to be protected with back up fuse. **Local requirements on the sum spark gap have to be followed in particular applications.**

Fu_1 - Fu_3 represent main protection (fuses, circuit breaker) in the installation. In case when $Fu_1, Fu_2, Fu_3 > \text{Max. back-up fuse for given SPDs}$, Fu'_1, Fu'_2, Fu'_3 have to be used. $Fu'_1, Fu'_2, Fu'_3 \leq \text{Max. back-up fuse of the SPDs}$. $Fu_4 \leq \text{Max. back up fuse of the sum spark gap } SPD_4$.